

ALL INFORMATION CONTAINED IN THIS DOCUMENT SHOULD BE USED FOR REFERENCE PURPOSES ONLY & ARE SUBJECT TO CHANGE WITHOUT PRIOR NOTIFICATION. ALSO, THIS DOCUMENT IS CONSIDERED PROPRIETARY & THE SOLE PROPERTY OF CRYOMECH, INC. & SHOULD NOT BE REPRODUCED IN ANY MANNER WITHOUT PRIOR WRITTEN APPROVAL.

B

B

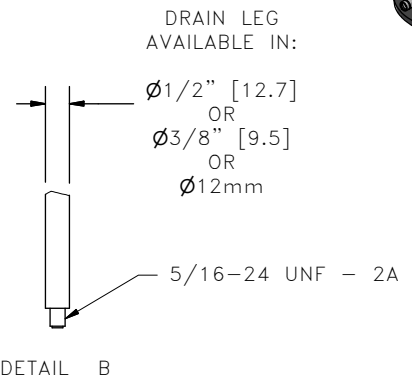
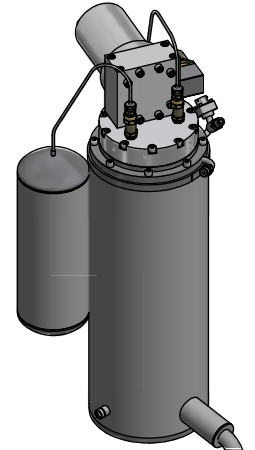
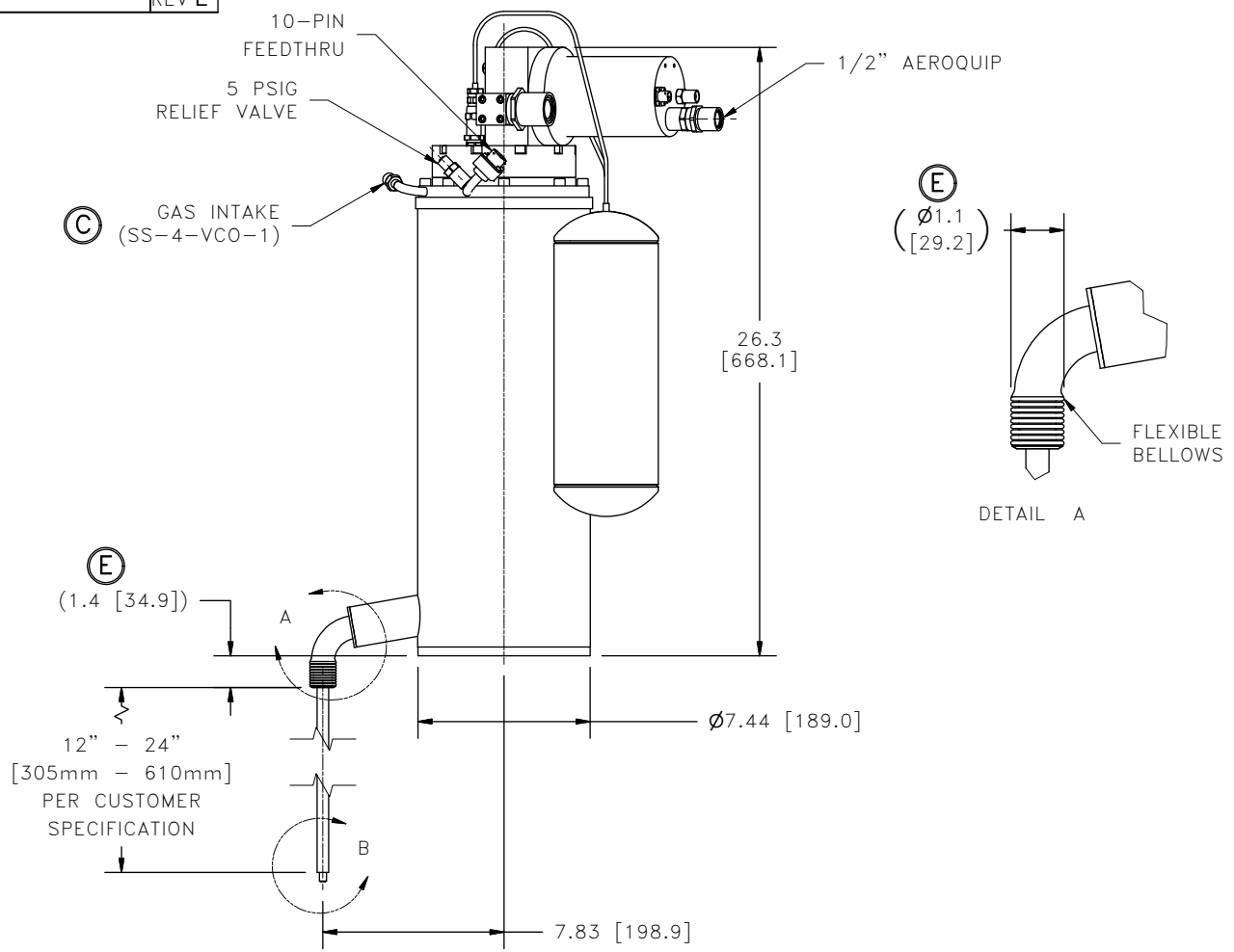

A

A

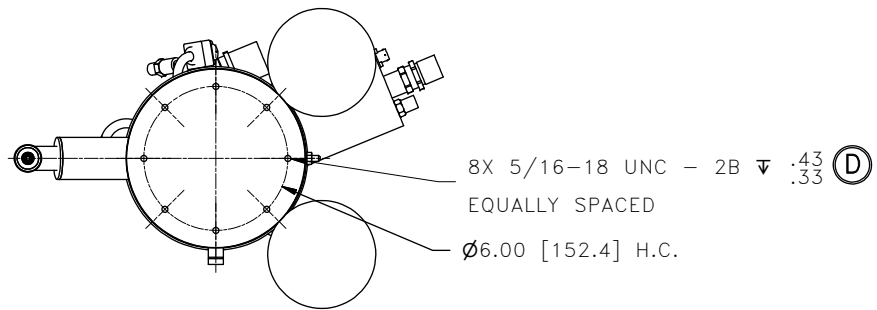

THIRD ANGLE PROJECTION

CRYOMECH, INC
 113 FALSO DRIVE SYRACUSE, N.Y. 13211
 Tel: (315)455-2555 Fax:(315)455-2544

ALL DIMENSIONS ARE IN INCHES
 TOLERANCES: FRACTIONS ±1/32 DECIMALS XXX=±.005 XX=±.01 X=±.1
 ANGLES ±.5° ALLOVER FINISH 25 Ra
 CONCENTRICITY .005 TOTAL INDICATOR RUN OUT
 PERPENDICULAR ±.002 (UNLESS OTHERWISE SPECIFIED)

NAME: HeRL12 RELIQUEFIER FINAL ASSY
 DWG #: HeRL10 SHT 1 OF 1
 MATERIAL: 107-01
 DWN BY: WAG DATE: 19JAN09 SCALE: 1/8 DWG SIZE: A
 1ST CHK: AO DATE: 1/20/09 2ND CHK: BZ DATE: 1/20/09
 CUST: - BTA: -

ECN	ZONE	REV	DESCRIPTION	DATE
4126	-	E	(Ø1.1) WAS Ø1.0, (1.4) WAS 1.3	20DEC17
4116	-	D	REVISED THREAD DEPTH TOLERANCE	13NOV17
3263	-	C	UPDATED GAS INTAKE FITTING	29JAN14

2

1